

# RAIN MASTER™ EAGLE PLUS Installation and Getting Started Guide

## Selecting the Controller Installation Site

The Eagle Plus controller in wall-mount cabinet is designed for indoor or outdoor environments, whereas pedestal-mount models are specifically designed for outdoor installation. Regardless of the enclosure type, selecting an installation site that provides user accessibility as well as basic protection from extreme hot or cold environments is considered good installation practice. At minimum, the installation site should provide the following:

- Protection from direct exposure to irrigation spray, midday sun, and snow accumulation
- Access to all required wiring connections
- Access to a dedicated, single-phase AC power source.

## Installing the Wallmount Enclosure Controller

1. Unlock and open the cabinet door, then open the hinged control panel. Position the controller on the wall at eye level, and mark the top and bottom mounting screw locations. See Figure 1.

Note: *Two stainless steel screws are provided for installation to a wall stud. If installing the controller on masonry or drywall, use the appropriate type screw anchors and fasteners. Install the screw anchors at 8¾" (22,23cm) (A) on center.*

**⚠ Caution: All cabinet openings required for installation and wiring are provided. Drilling or cutting through the cabinet should be avoided. Metal chips and filings entering the cabinet can damage internal components.**

2. Install the top mounting screw (B) leaving a ¼" (6,4mm) gap between the screw head and wall.
3. Hang the controller on the mounting screw, ensuring the screw is located at the top of the cabinet keyhole slot. Install the lower mounting screw (C), then tighten both screws securely.

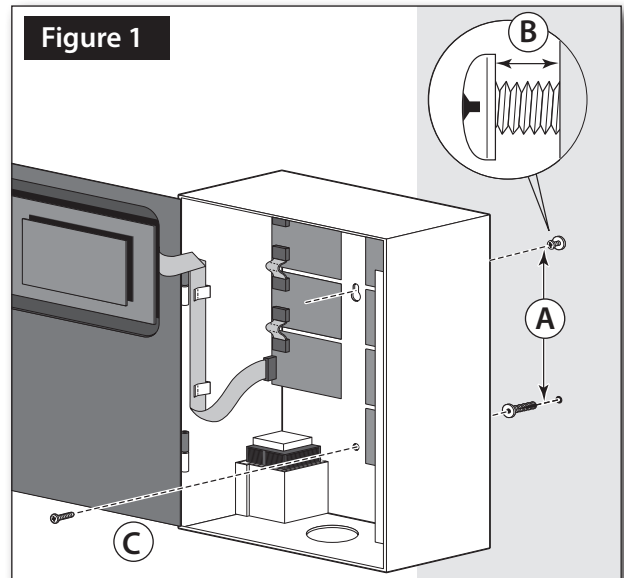

## Installing Electrical Conduit

Note: *Electrical conduit installation must comply with all applicable NEC and local electrical codes.*

1. Remove wiring terminal block cover (1). Install electrical conduit from the power source circuit breaker panel to the controller location. Attach conduit to bottom of cabinet using the ½" / ¾" (13mm / 19mm) access opening (2).
2. For field wiring, attach 2" or 3" (51mm or 76mm) conduit to cabinet using center access hole (3).
3. An additional ½" / ¾" (13mm / 19mm) access hole (4) is provided for auxiliary wiring.

Note: *Install optional ProMax antenna using access opening (5), and/or access opening (6) for the iCentral antenna.*

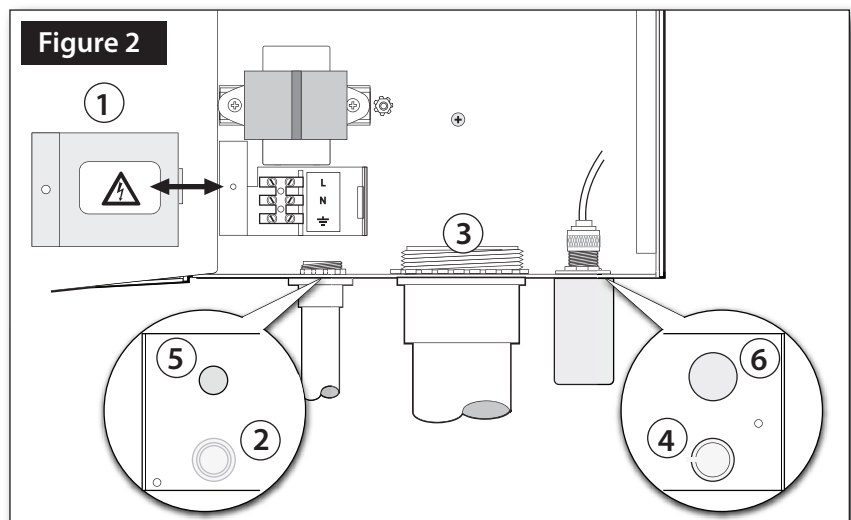

### Connecting Input Power Wiring

**⚠️ WARNING:** All electrical service installation components and methods must comply with NEC and local electrical codes that apply. GFCI protection is required on all equipment operated in wet locations. Most codes require a means in the fixed wiring of disconnecting the AC power mains with a mechanical contact separation of at least 0.120" (3mm) in the line and the neutral poles. The connection wire must have insulation rating of 221°F (105°C) minimum. **CONFIRM THAT THE AC POWER SOURCE IS OFF PRIOR TO CONNECTING WIRES.**

1. Ensure the power is disconnected at the source. See Warning above.
2. Remove the terminal block cover, located below the transformer.
3. Route the AC power and equipment ground wires through electrical conduit into the controller.
4. Strip wire ends to expose 3/8" (9,5mm) bare copper wire.
5. Using a small flat-blade screwdriver, secure wires to the terminal connectors as shown in Figure 3 and as follows:  
Line (black) to L, Neutral (white) to N, and Equipment Ground (green) to Ⓧ.

6. Install and secure terminal block cover.

Note: Do not apply power to the controller until all remaining installation procedures have been completed

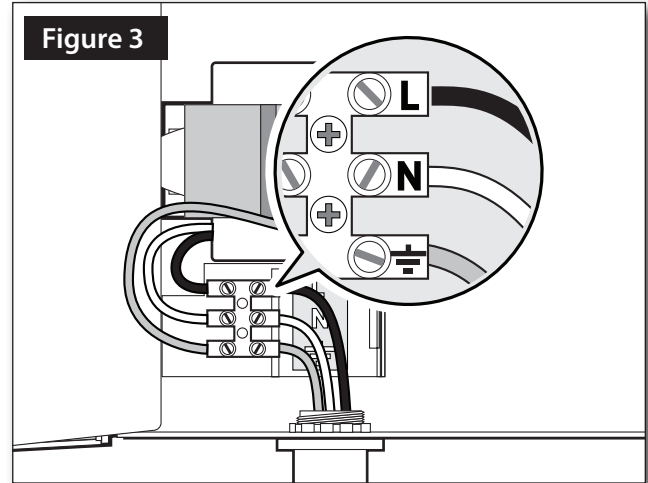

### Installing the Pedestal Enclosure Controller

1. Prepare a concrete mounting slab per the dimensions shown in Figure 4. Use the provided template to properly position four stainless mounting bolts and wiring access conduit into slab. Allow concrete to harden sufficiently before continuing.

Note: Although the SPED and PSB pedestal base footprints vary slightly, the same mounting bolt pattern shown applies to both pedestal styles.

2. Unlock and raise pedestal lid to remove pedestal door. Position the pedestal on the slab, aligning the mounting bolts with the holes in the pedestal base. Place a stainless washer and nut on each stud and tighten securely.

### Connecting Input Power Wiring

**⚠️ WARNING:** All electrical service installation components and methods must comply with NEC and local electrical codes that apply. Most codes require a means in the fixed wiring of disconnecting the AC power mains with a mechanical contact separation of at least 0.120" (3mm) in the line and the neutral poles. The connection wire must have insulation rating of 221°F (105°C) minimum. **CONFIRM THAT THE AC POWER SOURCE IS OFF PRIOR TO CONNECTING WIRES.**

1. Install a conduit box to the base of the power supply unit (1/2" NPT nipple) and 1" conduit (AC). See Figure 5.
2. Ensure the power is disconnected at the source. Confirm the

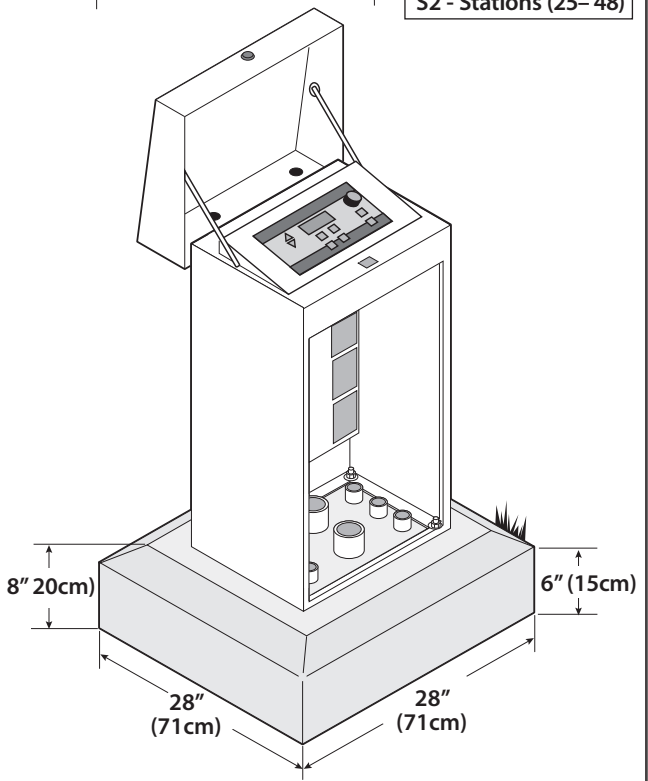
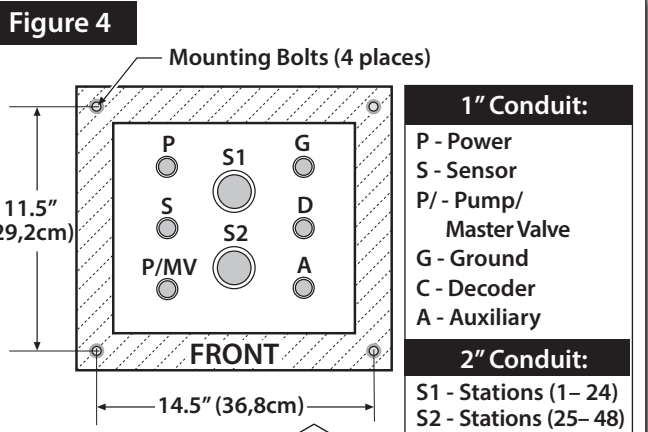

On/Off power toggle switch in the OFF (down) position.

3. Remove top screw from conduit box cover and position cover to the side.
4. Route the AC power and equipment ground wires from the source into the controller conduit box.
5. Strip wire ends to expose  $\frac{3}{8}$ " (9,5mm) bare copper wire.
6. Using insulated wire splice connectors, connect the wires as follows:  
Line (Hot) to Black, Neutral (Common) to White, and Equipment Ground to Green.
7. Close and secure conduit box cover.

Note: *Internal component arrangement will vary per controller model. All wiring connection procedures including AC power, earth ground, station output, field auxiliary, and two-wire decoder are applicable to all Eagle Plus controller models.*

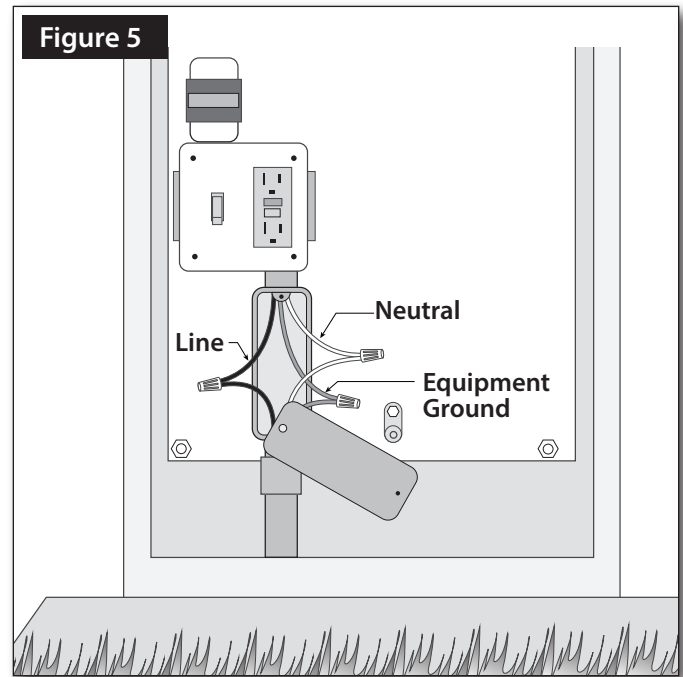

### Connecting an Earth Ground

**⚠ IMPORTANT:** The provided surge protection components cannot properly function unless a low-resistance connection to earth ground is provided. It is the responsibility of the installer to connect the Eagle Plus controller to earth ground in compliance with all applicable NEC and local electrical codes.

Note: *The grounding method described below utilizes a copper-clad ground rod electrode. Due to variables in soil composition and terrain, additional and/or alternate ground electrode types may be required to achieve the required maximum resistance of 10 ohms. Contact a local Irritrol distributor for grounding methods recommended for the specific installation site.*

1. Drive a  $\frac{5}{8}$ " by 10' (17mm x 3m) copper-clad steel rod into well-moistened soil, not less than 8' (2.5 m) or more than 12' (3.7 m) from the controller. The top of the ground rod should be buried approximately 12" (30.5cm) below grade.
2. Route a 6 AWG (13,0mm<sup>2</sup>) solid copper wire connected to the earth ground device into the controller cabinet through the access hole provided below the copper ground lug. Insert and secure the copper wire to the ground lug. See Figure 4.

Note: *To provide the most efficient path to earth ground, route the ground wire between the ground rod and controller with the least amount of bending possible. There should be no tight radius bends, nicks or deep scratches on the entire length of the wire.*

3. For optimum connectivity, secure the ground wire to the ground rod using a Cad-Weld™ (or equivalent) metal-fusion connection method.
4. Using an earth-ground resistance tester; i.e., Meggor® or equivalent, confirm the resistance reading between the controller and ground rod is 10 ohms or less.

Note: *Contact your local Irritrol distributor for assistance in obtaining the earth ground-resistance test device. Periodically retest the earth ground connection to confirm that resistance remains at 10 ohms or less.*

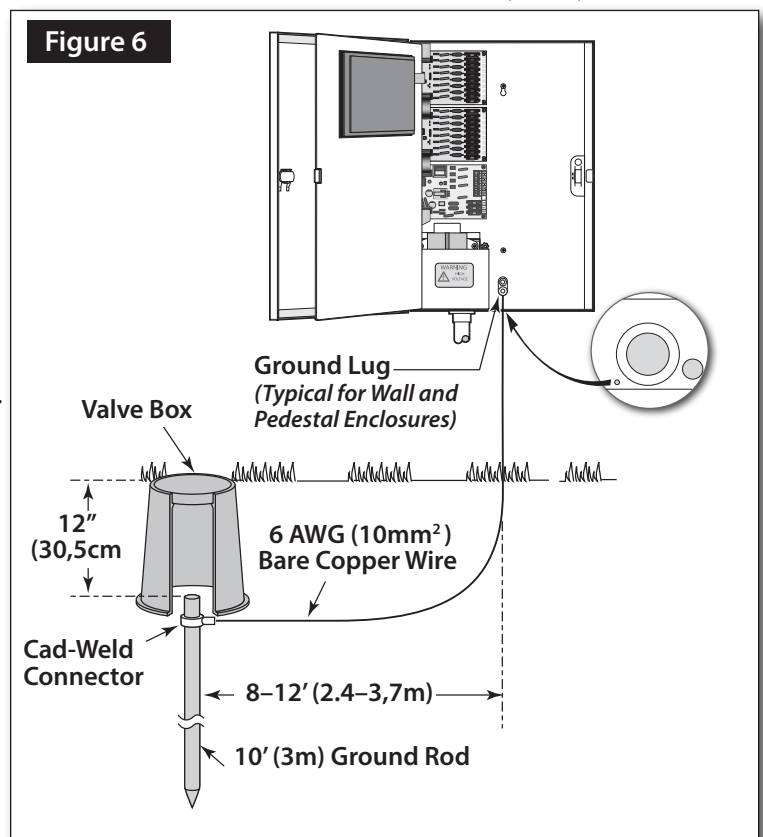

## Connecting Field Wiring

**⚠ Caution:** The Eagle Plus transformer is rated at 24 VAC, 50 VA. The controller can be programmed to operate up to 8 programs concurrently (one station per program), in addition to a master valve, and a pump relay – totaling 10 concurrent field output loads.\* Each station output terminal is rated 24 VAC, 0.5A (max.) @ 77°F (25°C), and capable of operating more than one valve solenoid (typically 2 or 3).\* Ensure the current load on any output does not exceed 0.5A, and the total current load imposed on the controller does not exceed 1.5A. The controller will automatically detect excessive current load and generate the appropriate alarm(s).

\*The irrigation system hydraulic capacity must be also be capable of maintaining adequate volume and pressure for all automatic and manual watering operations.

### Connecting Station Valves and Master Valve

The Eagle Plus features direct-insertion, quick-release wire terminals for all low-voltage wire connections. Each field output terminal accepts a 14–18 AWG (2,08mm<sup>2</sup> – 0,823mm<sup>2</sup>) solid-core wire in each of two connection ports – enabling two field wires to be connected independently to one terminal position.

- For positive wire retention, remove insulation to expose ½ – 5/8" (13–17mm) bare copper wire.
  - After insertion into terminal block, pull lightly on each wire to confirm positive retention. To release, depress the small tab (nearest the wire) using a small blade screwdriver.
  - Use waterproof connectors on all field wire splices to prevent corrosion and possible short circuit.
  - Ensure all exposed wiring inside the controller is taped back and properly insulated.
1. Route a separate control wire from each station output terminal and the Master Valve terminal (if applicable) to the corresponding valve location. Using a waterproof wire splice connector, attach the control wire to either valve solenoid lead.
  2. Route field common wire(s) from the controller's multiple COM terminals as required to interconnect the remaining lead of each valve solenoid to the field common circuit.

Note: To assist in identifying field wire connections using 24 VAC, see Identifying Field Wire Connections on page 7.

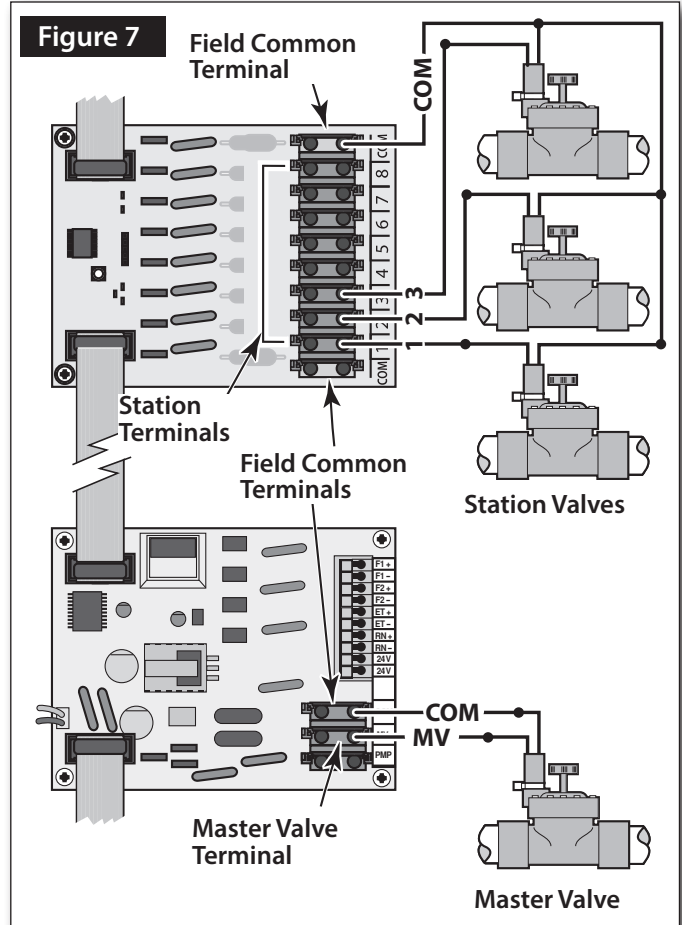

### Connecting a Pump Control

**⚠ Caution:** Do not be connect the controller directly to the pump motor or starter. A 24 VAC isolation relay; i.e., Irritrol SR-1 Pump Start Relay (or equivalent), must be used to facilitate the pump control circuit connection.

1. Install a 24 VAC pump start or equivalent isolation relay. Route and connect a control wire and a common wire from the Pump terminal of the Pump/Master Valve terminal block to the relay. See Figure 8.
2. Connect the remaining pump wiring per the instructions provided by the pump equipment manufacturer.

**⚠ Caution:** If multiple controllers are utilized within the irrigation system, do not interconnect the controllers' field common, pump or master valve wires. Damage to the controllers can result.

Note: Contact technical support at 1-800-777-1477 for information regarding multiple-controller wire connections.

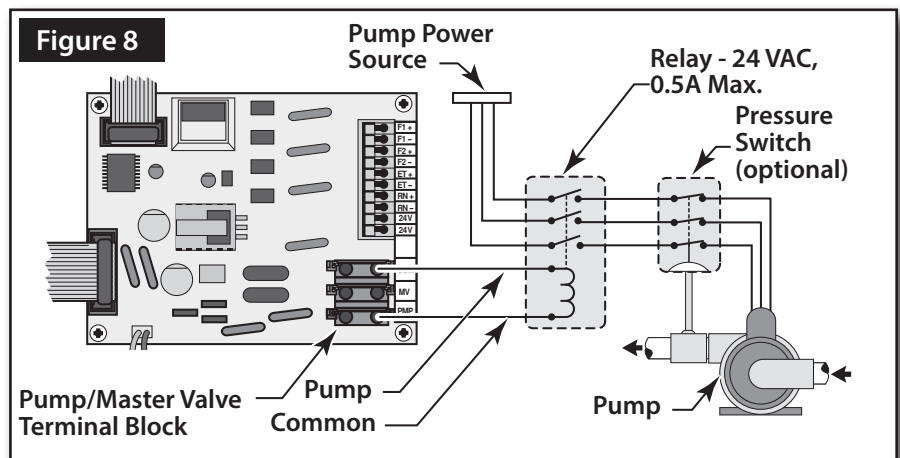



## Connecting Sensors

The Eagle Plus controller provides connection terminals for two flow sensors, a Rain Master Weather Center II or an Irritrol Rain/Freeze sensor. Installation of this equipment must be made in accordance with the instructions provided with each device. The wire connections to the controller are made per the diagram in **Figure 9**.

**⚠ Caution:** To prevent damage to the controller and/or sensor equipment, turn off power to the controller prior to connecting sensor wires.

Installation Notes:

- The sensor connection terminals accept 18–22 AWG (0,8mm<sup>2</sup>–0,5mm<sup>2</sup>) solid-core copper wire. To enable positive wire retention, insulation must be removed from the end of each wire to expose 3/8 – 1/2" (10–13mm) bare copper wire.
- Flow sensors and Weather Center II connection wires have specific polarity that must be maintained for proper operation of these devices. Note the + /– indicators on each sensor connection terminal and connect accordingly.
- The controller can support input from the Weather Center II weather station and an Irritrol rain or rain/freeze sensor. Both sensor inputs can be used together.
- A jumper wire installed between the RN(+) and RN(–) terminals must not be removed unless a (normally-closed) rain sensor is connected.
- Refer to the Eagle Plus User's Guide for information regarding compatible flow sensors and corresponding setup parameters.

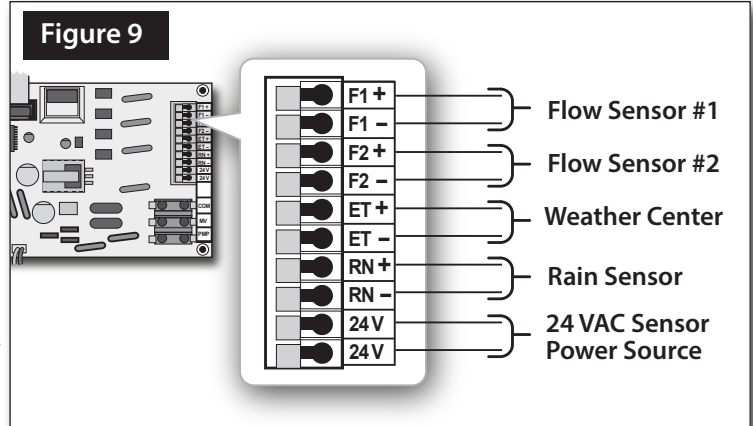

## Connecting a Two-Wire Decoder System

### Programming the Decoders

Rain Master decoders are configured in 1-, 2-, and 4-station models, and as shipped from the factory, have no pre-defined station assignments. In order to be recognized by the Eagle Plus controller, each station must be defined as either a station number from 1 to 200, a Master Valve control, or a Pump control. To facilitate decoder programming, a quick-connect terminal block is provided on the Two-Wire Decoder module board. See **Figure 10**.

Note: The Eagle Plus enables the decoders to be temporarily connected and programmed without disconnecting power.

1. Insert the red and black decoder wires into the corresponding terminal block positions.
2. Press the SETUP key to display the SETUP menu. The CONTROLLER menu item is chosen by default. Turn the Dial right five steps to choose the TWO-WIRE menu option, then press the Dial to select.

```

SETUP:
-CONTROLLER-  -FLOW-
-PROGRAM-     -COMM-
-ET-          -> [TWO-WIRE] ↑
    
```

3. The SETUP TWO-WIRE [PROGRAM DECODER] menu screen is displayed with PROGRAM DECODER option chosen by default. Press the Dial to select. Status LEDs on the decoder and decoder board will begin blinking to confirm communication.

```

SETUP TWO-WIRE
[PROGRAM DECODER] ←
-SHOW STATIONS-
-TEST-             ↑
    
```

4. The PROGRAM DECODER screen will be displayed with the NEW ADDRESS option chosen.

Note: In this example, NONE indicates that decoder station slot 1 (1 of 4 available slots) has no existing address.

5. To select a different decoder station slot number, turn the Dial to choose the slot number, then press the Dial to select. Turn the Dial to display the preferred number, then press the Dial to enter.

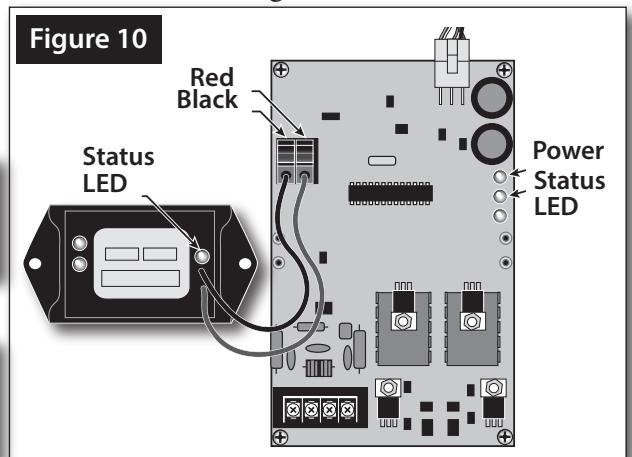

```

PROGRAM DECODER:
CURRENT ADDRESS: NONE
NEW ADDRESS [NONE] ←
-> 1- OF 4 -PROGRAM- ↑
    
```

```

PROGRAM DECODER:
CURRENT ADDRESS: NONE
NEW ADDRESS [NONE]
-> 2] OF 4 -PROGRAM- ↑
    
```

6. Press the Dial to choose NEW ADDRESS: NONE. Turn the Dial to display the preferred address, then press the Dial to enter. *In this example, station number 12 will be assigned to decoder station slot 2 of 4.*
7. Turn the Dial to choose PROGRAM, then press the Dial to begin the procedure. Within a few moments the results will be displayed. If programming was successful, OK will be momentarily displayed in the upper right corner, and the next decoder station number in sequence will be displayed. If programming was not successful, FAIL will be displayed and an alarm will be generated.



Note: To clear the Alarm, press the HOME key, turn the Dial to choose ALARMS, then press the Dial to view Alarm information. Turn the Dial to choose CLEAR, then press the Dial select. Check decoder wire connections and repeat the procedure.

8. Repeat the programming procedure for all decoder stations as required.

### Connecting the Decoders

Installing a decoder system requires a different approach to field installation compared to a conventional multi-wire irrigation control system. The main differences include:

- A two-wire cable provides power and communication signals from the controller to up to 100 decoders for individual control of up to 202 field outputs.
- The two-wire cable system can be configured in one of three methods: straight line, grid or loop, as illustrated in the accompanying diagrams:

**Legend**

**A** TW-LA-1 lightning arrestors must be connected throughout the two-wire path at intervals of 600' (183m) or less. *The same grounding requirements as specified for the controller are required for each lightning arrestor.*

**B** The cable wire path from the furthest decoder to the controller cannot exceed 5000' (1.54km).

**C** The cable wire length from the decoder to the valve (or pump) must not exceed 100' (30m).

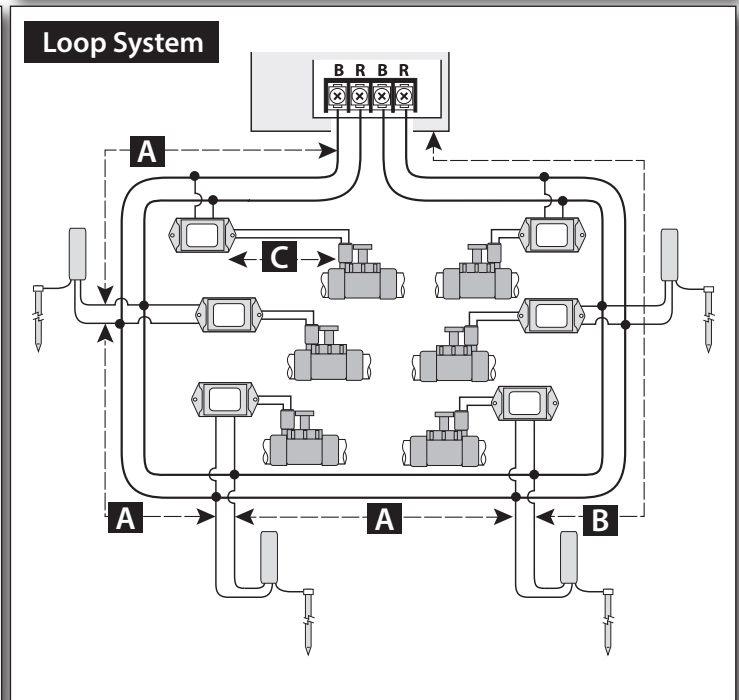
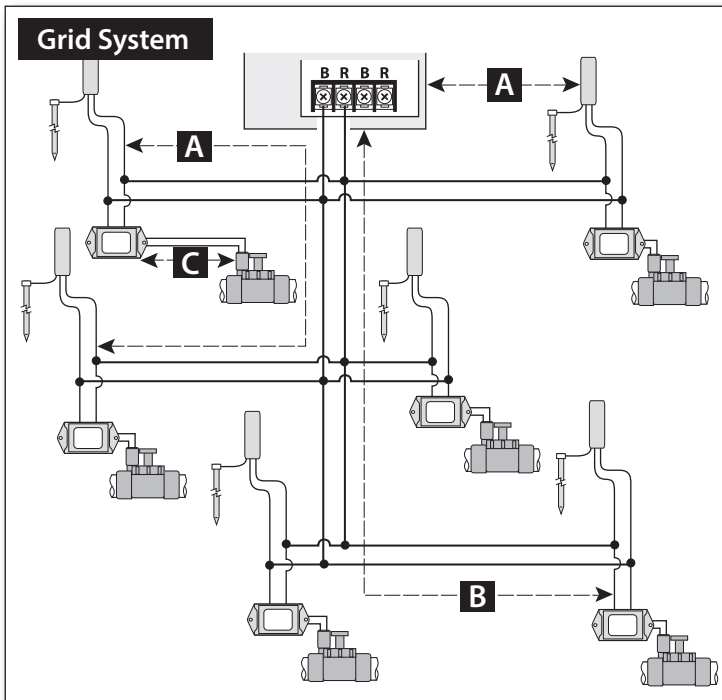
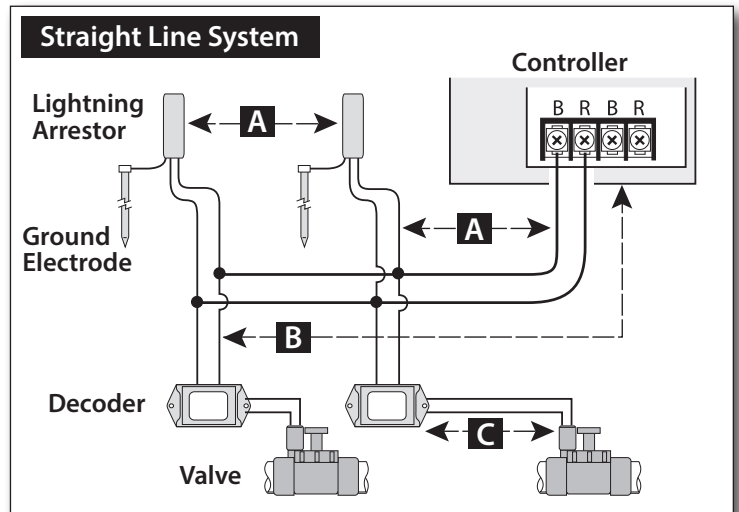

**Key Decoder Installation Practices**

**Key 1**

All communication cable splices must always follow the color code. Black wires must be connected to black wires, red wires to red wires.

For ease of troubleshooting and service, it is recommended to run multiple paths out of the controller.

**Requirements**

- TW-CAB-14 – 14-gauge, two-wire direct-burial communication cable (or equivalent) is required for decoder connection.
- Two-wire cable wire color polarity must be maintained throughout the system and connected to the corresponding controller terminals.
- All wire splices and field connections must be insulated using TW-SPLICE-14 waterproof wire connectors (or equivalent).

Note: Refer to **Two-Wire Decoder System Specifications** page 14 for additional important information regarding decoder system installation requirements.

**Key 2**

All valves must be equipped with standard 24 VAC solenoids. Replace the solenoid if necessary.

24 VAC solenoid

**Key 3**

All decoder to solenoid wires must be connected with the correct station wire to properly operate the correct solenoid.

If the station output wires are not being used, install a wire nut on each wire and place in DBRY-100.

**Key 4**

Waterproof all communication cable splices using DBRY-100 or equivalent.

**Testing the Decoder System**

The purpose of the test is to verify the functionality of each decoder station and its associated valve solenoid. Alarm log entries can be generated to locate and resolve decoder system issues and/or archive the test results for later review. See **Testing the 2-Wire Decoder System** on page 13 for complete information.

Part No.	Description	Part No.	Description
TW-D-1	Single Valve Decoder	TW-SPLICE-14	Waterproof Wire Splice
TW-D-2	Dual Valve Decoder	TW-CAB-14	14-Gauge, 2-Wire, Direct-Burial Cable
TW-D-4	Quad Valve Decoder		
TW-LA-1	Lighting Arrestor		

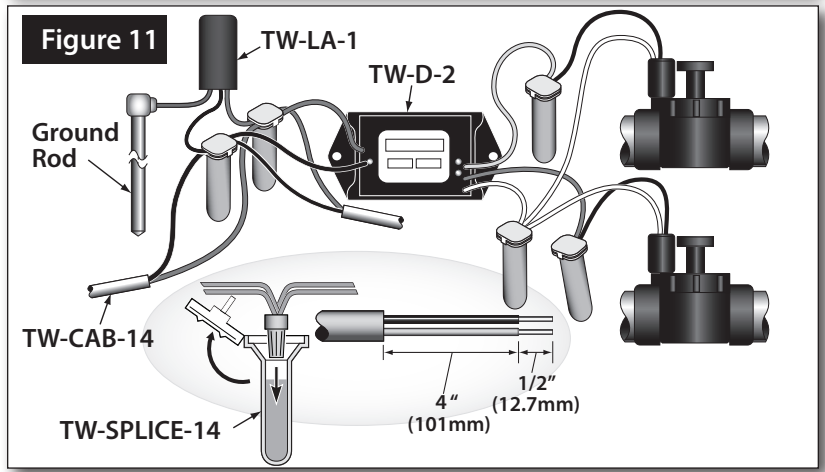



**Getting Started - Control Module Overview**



**1- LCD Display**

The large format LCD display presents all setup, programming, system control and monitoring functions in an interactive menu-driven format.

Note: To conserve power, the LCD backlight dims automatically after five minutes of inactivity. The backlight is restored automatically with any controller input.

The Home screen is displayed by default when the controller is in the standby mode to provide basic controller status information.

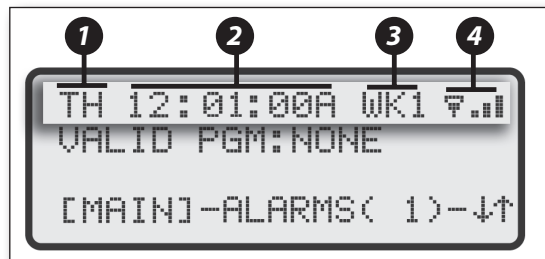

The top line of the Home screen provides the current day **1**, time **2**, and week **1**

or 2 of the two-week watering schedule **3**. When equipped the optional iCentral modem, an antenna symbol with signal strength bars will be shown **4**.

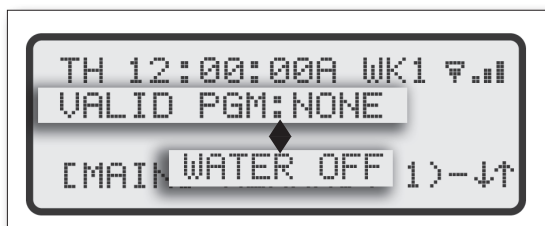

The second line indicates the current number of configured automatic programs:

1–8 or None for standard systems, or 1–16 or None for Two-Wire systems. *When the controller is in the Water Off mode, WATER OFF is displayed*

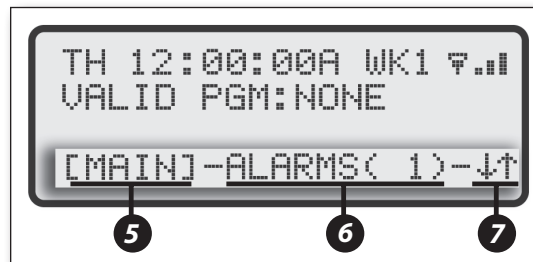

The bottom line of the Home screen provides: Main menu access **5**, pending number of alarms **6**, and display sequence arrow(s) **7**.

pending number of alarms **6**, and display sequence arrow(s) **7**.

**2-Screen Sequence Keys**

The  $\nabla$  Next and Back  $\triangle$  screen sequence keys are tied to the corresponding  $\downarrow$  and  $\uparrow$  arrow symbols when displayed. Pressing the associated sequence key provides forward or backward access through the screen sequence.

**3- Irrigation and Alarm Monitors**

The Irrigation LED monitor illuminates to indicate system watering activity. The Alarm LED monitor illuminates when a system Alarm is generated. The Alarm monitor will remain on until the user clears all alarms. An audible alarm option can be enabled that will “chirp” every six seconds to indicate one or more pending alarms.

**4- Selection Dial**

The selection Dial is the main user-interface component, providing a single rotary/push-button dial to select and input all controller setup and operating features.

5 - Direct Access Menu Keys

Direct access to each primary menu function is provided by pressing the corresponding selection key as follows:

 **PROGRAM Key** – Selects the MAIN PROGRAM menu. Provides program-related options including: new program setup, existing program review, program modification, deletion, and copy functions.

 **SETUP Key** – Selects the MAIN SETUP menu. Provides setup menus for CONTROLLER operating preferences, FLOW monitor setup, PROGRAM operating preferences, COMM setup, ET setup, and TWO-WIRE system setup.

 **MANUAL Key** – Selects the MANUAL OPERATIONS menu enabling manual control including: single STATION and MULTI-STATION operation, manual PROGRAM start/stop and station sequence TEST functions.

 **REVIEW Key** – Selects the REVIEW menu to access controller software/firmware version and operating data logged for: PROGRAMS, ALARMS, FLOW, and ET.

 **HOME Key** – Returns directly to the HOME menu from any location within the menu hierarchy.

6 -  **WATER OFF Key** – Terminates all automatic watering activity. When selected, all current automatic controller operation shuts down and remains off until WATER OFF mode is released. The Water Off LED monitor illuminates when the controller is in the WATER OFF mode.

7 - Pro Max Remote Control Receptacle – Provides easy connection for Pro Max receiver cable.

**Selecting Controller Setup Options**

The controller setup options determine how the controller displays and manages the various tasks required to control and monitor your irrigation system.

A set of default controller setup and operating preferences is established on initial power-up. The table below lists the various controller setup menu items, the available options and the factory default settings.

Setup Menu	Option	Default
Current Time	Numeric Value, AM/PM	12:00:00 a.m.
Current Date	Alpha/Numeric	Thursday, 01/ 01/2009
Clock Format	12- or 24-Hour	12-Hour
Access Code	4-Digit Numeric	0000
Program Stacking	Yes or No	Yes
Stacking Limits	1 to 8 Programs	3 Programs
Station Delay	0–19 min, 0–59 sec	0 min, 0 sec
Master Valve Config.	NC or NO	NC (normally closed)
Units Format	U.S. Standard or Metric	U.S. Standard
Date Format	mm/dd/yy or dd/mm/yy	mm/dd/yy
Odd/Even Days Off	Yes or No	No
Rain Days Off	1–9 or None	None
Water Window	0–24 Hours	24 (12:00 a.m.–11:59 p.m.)
Audible Alarm	On or Off	Off

## Setting the Time and Date

Note: Synchronizing the controller with the current date and time should be accomplished first. The remaining settings can be changed at any time. Some of the settings will influence corresponding programming and controller operations. These features are explained in detail within the applicable portion of the User's Guide.

Upon initial power-up and after the controller has been without power for an extended period of time, the SETUP DATE/TIME screen is displayed by default. Enter the actual time and date per the following step-by-step procedure. When you have completed this initial procedure, you will be familiar with the Eagle Plus menu structure and how the multifunctional Dial allows you to easily navigate to select, change, adjust and enter the various controller programming and setup options.

**⚠ Important: All setup and programming selections must be entered (saved to memory) by pressing the Dial before pressing any of the Direct Access keys. The controller will disregard any selection that has not been saved.**

Note: An audible "chirp" tone is generated each time a valid Key or Dial entry is made. An invalid action is indicated by the chirp tone four times in rapid succession.

Note: Menu items displayed between dashes can be selected. Turn the Dial in either direction to choose (bracket) the menu item, then press the Dial to select.

1. The controller will display the SETUP DATE/TIME screen upon power up.

```

SETUP DATE/TIME:
DATE: [01/01/09] ←
TIME: -12:00AM-
FORMAT: -12 HOUR- ↑
    
```

2. Press the Setup  key to display the SETUP menu.

```

SETUP:
[CONTROLLER] ← FLOW-
-PROGRAM- -COMM-
-ET- -TWO-WIRE- ↑
    
```

3. Press the Dial to select the CONTROLLER menu. The DATE/TIME option is chosen by default.

```

SETUP CONTROLLER:
[DATE/TIME] ← ACCESS-
-STACK- -DELAY-
-MVALVE- -MORE- ↓ ↑
    
```

4. Press the Dial to select and display the SETUP DATE/TIME screen. The DATE option is chosen by default.

```

SETUP DATE/TIME:
DATE: [01/01/09] ←
TIME: -12:00AM-
FORMAT: -12 HOUR- ↑
    
```

Note: In this example, date and time will be changed the default setting to June 15, 2011, 2:45

5. Press the Dial – the Month digits (01) will begin flashing.

```

SETUP DATE/TIME:
DATE: [01/01/09]
TIME: -12:00AM-
FORMAT: -12 HOUR- ↑
    
```

6. Turn the Dial to display the current month (06 = June), then press the Dial to enter the change. The Day digits (01) will begin flashing.

```

SETUP DATE/TIME:
DATE: [06/01/09]
TIME: -12:00AM-
FORMAT: -12 HOUR- ↑
    
```

7. Turn the Dial to display the current day (15), then press the Dial to enter the change. The Year digits (09) will begin flashing.

```

SETUP DATE/TIME:
DATE: [06/15/09]
TIME: -12:00AM-
FORMAT: -12 HOUR- ↑
    
```

8. Turn the Dial to display the current year (11), then press the Dial to enter the change.

```

SETUP DATE/TIME:
DATE: [06/15/11] ←
TIME: -12:00AM-
FORMAT: -12 HOUR- ↑
    
```

9. Turn the Dial right one step to choose Time, then press the Dial to select. The current hour digits will begin flashing.

```

SETUP DATE/TIME:
DATE: -/15/11-
TIME: [12:00AM]
FORMAT: -12 HOUR- ↑
    
```

10. Turn the Dial to display the current hour (02:), then press the Dial to enter the change. The minutes digits will begin flashing.

```

SETUP DATE/TIME:
DATE: -/15/11-
TIME: [02:00AM]
FORMAT: -12 HOUR- ↑
    
```

11. Turn the Dial to display the current minute (:45), then press the Dial to enter the change. The AM designator will begin flashing.

```

SETUP DATE/TIME:
DATE: -06/15/11-
TIME: [02:45AM]
FORMAT: -12 HOUR- ↑
    
```

12. Turn the Dial to display PM, then press the Dial to enter the change.

```

SETUP DATE/TIME:
DATE: -06/15/11-
TIME: [02:45PM]
FORMAT: -12 HOUR- ↑
    
```

13. Press the Home  key to exit the SETUP menu.

Note: The initial Alarms shown on the Home screen are generated by default during the power-up process and not indicative of a problem. Clear the Alarms as follows:

- Turn the Dial right one step to choose ALARMS.

```

TH 02:45:39P WK1 7.11
VALID PGM: NONE
-MAIN → [ALARMS< 1>]
    
```

- Press the Dial to select ALARMS.

- The cause of the alarm will be displayed. Press the Dial as needed to clear the Alarm(s).

```

TH 02:45:39P WK1 7.11
POWER RESTORED
→ [CLEAR] ↑
    
```

## Identifying Field Wire Connections

**⚠ Caution:** The method of field wire identification by momentarily contacting a field control wire to an energized output terminal can damage the solid-state components of the Eagle Plus controller, and must not be used.

An alternate similar method that can be used safely with the Eagle Plus is accomplished as follows:

1. Press the MANUAL  key to display the MANUAL OPERATIONS screen. The manual STATION option is chosen by default

```
MANUAL OPERATIONS:
[STATION] ← PROGRAM-
-MULTI STATION-
-TEST-
```

2. Press the Dial to select STATION – the next MANUAL OPERATIONS screen in sequence will be displayed. Station 1 is selected by default.

```
MANUAL OPERATIONS:
STATION 1 ←
RUNTIME-00:00-
-START- ↑
```

3. Turn the Dial right one step to choose the RUN TIME value. Press the Dial to select the time value– the hours digits will begin flashing. Turn the Dial right one step to display one hour (01:00). Press the Dial to enter– the minutes digits will be selected. Simply press the Dial to enter 00 minutes for this procedure.

```
MANUAL OPERATIONS:
STATION- 1-
RUNTIME[01:00] ←
-START- ↑
```

4. Insert the control wire you wish to identify to station 1 terminal.

5. Turn the Dial right one step to choose START, then press the Dial to begin operation.

```
MANUAL OPERATIONS:
STATION- 1-
RUNTIME- 1:00-
[START] ← ↑
```

The Irrigation LED will illuminate, and the remaining run time for STATION 1 will begin counting down. Note the corresponding sprinkler operation.

6. Deactivate Station 1 by pressing the Dial to toggle from START to STOP.

```
STATION: 1 00:59:45
MVALUE:OFF PUMP:OFF
[STOP] →
-NEXT- -PREVIOUS- ↑
```

7. Remove the control wire, then repeat steps 4–6 to test the remaining control wires as needed.

8. When finished press the HOME  key to return to the Home screen.

```
TH 02:45:39P WK1 7.11
VALID PGM:NONE
[MAIN]
```

## Testing the Two-Wire Decoder System

The Two-Wire Decoder system test feature provides methods of testing the decoder installation to easily verify communication, station assignment and operating status and log the results. The following test options are available:

- **Single Station:** Tests a selected Decoder station number.
- **Find Decoders:** Tests and displays all controller stations with an associated decoder address.
- **All Programmed:** Tests all decoder stations with a defined address (1–200, Master Valve or Pump).
- **All Stations:** Tests all decoder stations, Master Valve and Pump controls.
- **Alarm Logging Options:** Test results can be logged as Alarms indicating Pass and/or Fail as selected.
  - **Log Fail Alarm:** When selected, a decoder station that fails the test criteria will be logged.
  - **Log Pass Alarm:** When selected, a decoder station that passes the test criteria will be logged

Note: *Only the Single Station Test procedure is provided in this guide. Refer to the Eagle Plus user's guide for Find Decoder, All Stations and All Programmed test procedures.*

### Single Station Test Procedure

1. Press the SETUP  key to display the SETUP menu. Turn the Dial to choose the TWO-WIRE option, then press the Dial to select.

```

SETUP:
-CONTROLLER- -FLOW-
-PROGRAM-    -COMM-
-ET-         ->[TWO-WIRE]↑
    
```

The SETUP TWO-WIRE menu screen is displayed with the PROGRAM DECODER option chosen by default.

```

SETUP TWO-WIRE
[PROGRAM DECODER]←
-SHOW STATIONS-
-TEST-           ↑
    
```

2. Turn the Dial to choose the TEST option, then press the Dial to select.

```

SETUP TWO-WIRE
-PROGRAM DECODER-
-SHOW STATIONS-
[TEST]←         ↑
    
```

3. The SETUP TWO-WIRE TEST screen is displayed with SINGLE STATION test type chosen by default.

```

SETUP TWO-WIRE TEST
TYPE=SINGLE STATION←
LOG FAILURES-YES-
LOG PASS-YES-   -GO-↑
    
```

4. Turn the Dial to choose the LOG FAILURES option. The YES option is selected by default. To *disable* this function, turn the Dial to display NO, then press the Dial to enter.

```

SETUP TWO-WIRE TEST
TYPE-SINGLE STATION-
LOG FAILURES[ NO]←
LOG PASS- NO-   -GO-↑
    
```

5. Turn the Dial to choose the LOG PASS option. The NO option is selected by default. To *enable* this function, turn the Dial to display YES, then press the Dial to enter.

```

SETUP TWO-WIRE TEST
TYPE-SINGLE STATION-
LOG FAILURES-YES-
LOG PASS[ NO]←-GO-↑
    
```

6. Turn the Dial to choose GO, then press the Dial to continue.

```

SETUP TWO-WIRE TEST
TYPE-SINGLE STATION-
LOG FAILURES-YES-
LOG PASS-YES-  ->[GO]↑
    
```

7. The SINGLE STATION TEST screen will be displayed with STATION 1 chosen by default. To change the station selection, press the Dial to select, turn the Dial to display the preferred station number, then press the Dial to enter.

```

SINGLE STATION TEST
STATION[ 1]←
-GO-↑
    
```

```

SINGLE STATION TEST
STATION[ 12]←
-GO-↑
    
```

8. Turn the Dial to choose GO, then press the Dial to start the test.

```

SINGLE STATION TEST
STATION- 1-
->[GO]↑
    
```

9. The test results will be displayed. Based on the Alarm Log options selected, an alarm may be generated.

```

SETUP TWO-WIRE TEST:
TESTING STATION: 12
TESTING CURRENT: .18
VERSION: 0 ->[STOP]↑
    
```

Note: *To pause or stop the test, turn the Dial to choose STOP, then press the Dial to pause the test. To resume the test, press the Dial again. To terminate the test, press the BACK  key.*

10. Press the HOME  key to return to the Home screen. Turn the Dial to choose ALARMS, then press the Dial to review the Alarm screen.

```

WE 02:47:41P WK1 7.11
VALID PGM:NONE
-MAIN-[ALARMS( 1)]
    
```

11. Turn the Dial to choose CLEAR, then press the Dial to clear the alarm.

```

06/16 WE 02:48:01P
STATION 12
DECODER FOUND
[CLEAR] ↑
    
```

Note: *Clearing alarms removes the screen prompts and extinguishes the Alarm LED indicator. Logged alarm information is accessible from the REVIEW menu screen.*



## General Specifications

### Cabinet Dimensions:

- Wall Mount: 11" W x 16" H x 5.625" D (27,9cm W x 40,6cm H x 14,29cm D)
- Pedestal Mount:
  - Style PSB: 16.5" W x 38" H x 17.25" D (41,9cm W x 96,5cm H x 43,8cm D)
  - Style SPED: 16" W x 34" H x 16" D (40,6cm W x 86,4cm H x 40,6cm D)

### Temperature Range:

- Operating: +14°F to +140°F (-10°C to +60°C)
- Storage: -22°F to +149°F (-30°C to +65°C)

### Power Specifications:

- Internal Transformer, Class 2, UL Listed, CSA Certified (or equivalent)
- Input: 120 VAC ± 10%, 50/60 Hz
- Output: 24 VAC ± 10%, 50/60 Hz
- GFI with On/Off Power Switch (pedestal enclosure models only)
- Maximum Load Per Station: 0.5A @ 24 VAC @ 77° (25°C)
- Maximum Load Per Master Valve: 0.5A @ 24 VAC @ 77°F (25°C)
- Maximum Load Per Pump Output: 0.5A @ 24 VAC @ 77°F (25°C)
- Total Maximum Load: 1.5A @ 24 VAC @ 77°F (25°C)

Output Surge Protection (excluding two-wire decoder models):

- 6KV common
- 1KV normal.

### Controller Memory:

The Eagle Plus utilizes NVRAM (Non-volatile Random Access Memory) technology to protect all user-defined program and setup data from loss in the event of a power failure. Time and date settings will be maintained without power for approximately 30 days.

## Two-Wire Decoder System Specifications

### Decoder Cable:

Note: *Rain Master communication cable, TW-CAB-14, is recommended. Twisted-pair, polyethylene-jacketed communication cable, and PVC-insulated, single-core "irrigation" wire is not proven to be reliable for Rain Master decoder system application, and is NOT recommended.*

- Two-conductor, 14-gauge, solid-core copper wire, double-jacketed insulation manufactured of high-density, sunlight-resistant polyethylene or UF-B UL PVC with a minimum wall thickness of 060" (1.5mm). A protective outer sheath must be manufactured of polyethylene or PVC material conforming to ICEA S-GL-402 or NEMA WC5, with a minimum wall thickness of .045" (1,2mm) and approved for direct burial installation.
- All wire insulation and conductors must be fully intact and free of nicks or cuts.
- A minimum wire size of 14-gauge (2mm<sup>2</sup>) is required for straight-line cable installation; i.e., wire distance to the furthest decoder not on a loop.

### Decoder Cable Configuration

To provide the optimum power and communication for system operation, the recommended wire path configuration is a continuous loop beginning and ending at the controller, and is often routed generally following the main water lines. The loop configuration provides a redundant path for decoder operation, allowing the system to continue operation even in the event of a damaged cable.

Other supported decoder cable path configurations include: straight line, looped, star, or a combination of these methods. Separate branch paths can be tapped from the main loop, and are not required to feed back to the main trunk line. A branch path can be configured as a loop, a star, or a single line. The Rain Master decoder system will function with most wiring configurations when the correct wire type, size, and length of run are within specification.

